

FLOOR TECHNOLOGY - Technical Bulletin

PRODUCT FEATURES:

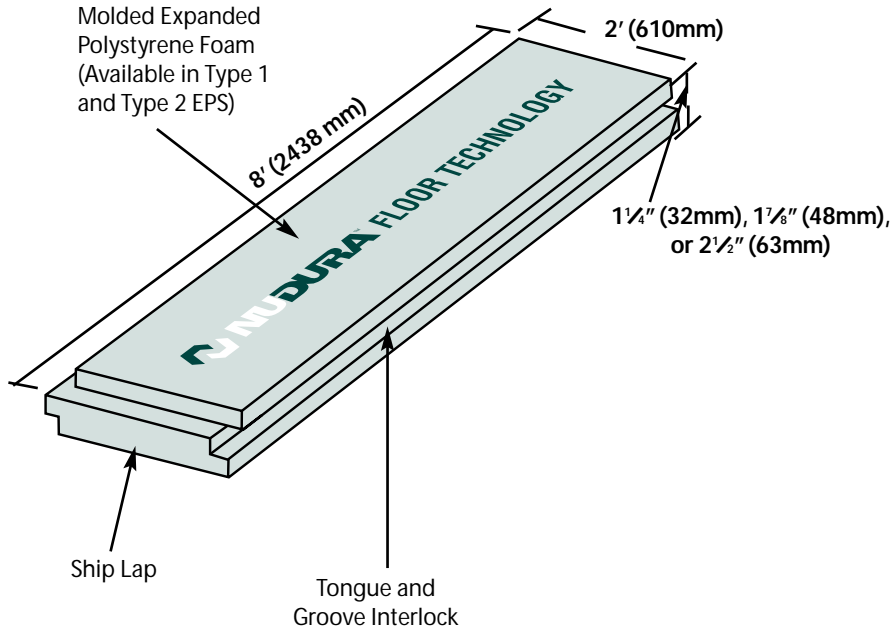

(1 1/4" (32mm) product is ship lapped on four sides)

TYPICAL NUDURA® CROSS SECTION:

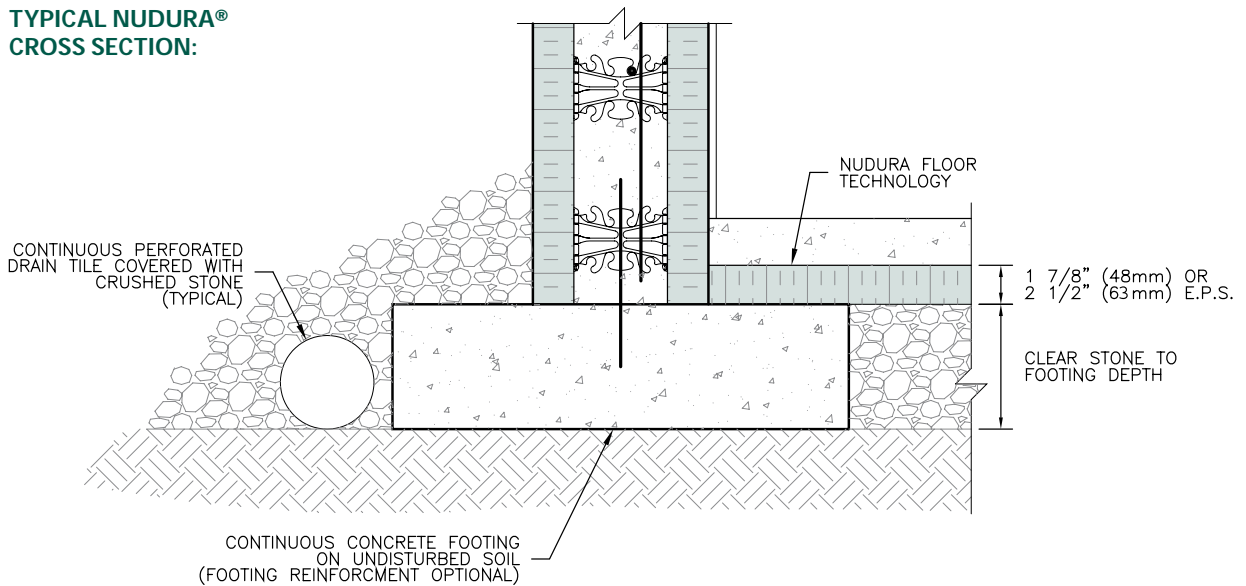

FLOOR TECHNOLOGY - Technical Bulletin

SUPERIOR PERFORMANCE

“NUDURA® Floor Technology is a durable and effective underslab insulation that is fast and economical to install.”

- Unique ship lap and tongue and groove integrity – no gaps and fast and easy installation
- Durable molded sheets resist the cracking and crumbling associated with wire cut products.
- Cost effective under-slab insulation performance.
- Contains no potentially harmful CFC's or HCFC's.
- Safe Handling
- 100% recyclable

TECHNICAL DATA

Physical Properties of molded EPS insulation	ASTM Test Method	ULC S701-97 Requirements (Type 1)	NUDURA® Floor Technology Type 1	ULC S701-97 Requirements (Type 2)	NUDURA® Floor Technology Type 2
Thermal Resistance (1" thick) hr.ft ² .°F/BTU (m ² .°K/w)	C-518	min.: 3.7 (min.: 0.65)	3.82 (0.67)	min.: 4.0 (min.: 0.70)	4.05 (0.708)
Water Vapor Permeability Perm. (ng/Pa.s.m ²)	E-96	max.: 5.3 (max.: 300)	0.70 (40)	max.: 3.5 (max.: 200)	0.60 (35)
Dimensional Stability %	D-2126	max.: 1.5	1.0	max.: 1.5	1.0
Flexural Strength lbs/ft ² (kPa)	C-203	min.: 25 (min.: 170)	80 (550)	min.: 35 (min.: 240)	84 (575)
Water Absorption %	D-2842	max.: 6.0	1.8	max.: 4.0	1.8
Compression Strength lbs/ft ² (kPa)	D-1621	min.: 10 (min.: 70)	14 (97)	min.: 16 (min.: 110)	19 (131)
Oxygen Limit Indication %	D-2863	min.: 24	42	min.: 24	41

INSTALLATION INSTRUCTIONS

- 1) Level the granular base to receive the panels.
- 2) Install panels against one wall, with the labelling upwards, making sure that the end of the panel with the ship lap is at the bottom to receive the next panel.
- 3) Once the pattern is established, use the orientation of the labelling to maintain the pattern.
- 4) It is recommended to stagger the 2' (610mm) seams. This is easily achieved by starting the second row with the leftover cut panel from the first row. This method will result in virtually no material waste.

PACKAGING AND ORDERING

- Two lines of NUDURA® Floor Technology are available – Type 1 EPS and Type 2 EPS.
- Available in 1 1/4" (32mm), 1 7/8" (48mm), or 2 1/2" (63mm) thicknesses.
- NUDURA® Floor Technology can also be custom manufactured at higher densities to meet job-specific requirements.

Packaging	Thickness	Pieces/Bundle
	1 1/4" (32mm)	17
	1 7/8" (48mm)	11
	2 1/2" (63mm)	8